

WOVEN WOOD

Installation Instructions

Thank you for purchasing this custom window shade. With proper installation, your shade should look beautiful and provide years of service. Please check all parts and read these instructions, before starting installation.

REPLACEMENT PARTS:

In the event that replacement parts are ever needed, please call **1-800-505-1905**. Please provide your original order number and a description of the part needed.

ONE YEAR LIMITED WARRANTY:

What is covered by this warranty and for how long:

For a period of one (1) year from the date of purchase, all products are warranted against defects in materials and workmanship provided that the product is installed according to the product instructions. We reserve the right to determine if your piece warrants a repair or partial replacement of any parts or in the unlikely event the entire piece is defective, we will replace this window covering with a new window covering of equal or superior value. This shall be your sole remedy under this warranty.

Who is covered by this warranty:

This warranty applies to the original customer with proof of purchase in a residential application within the United States.

What is not covered in this warranty:

This warranty does not cover removal or installation or reinstallation of any window covering. This warranty does not cover damage or defects caused by or resulting from improper maintenance, neglect or improper use, abuse, misuse, neglect, accidents, Acts of God, alteration, commercial use, installation, removal or reinstallation or exposure to excessive moisture.

Your rights under State Law:

This warranty gives you the specific legal rights. You may also have other rights which may vary from state to state. Blinds.com will not be liable for **INCIDENTAL OR CONSEQUENTIAL DAMAGES** or for any other direct or indirect damage, loss, cost, expense or fee. Some states do not allow the exclusion or limitation of incidental or consequential damages, so the above limitation or exclusion may not apply to you.

How to obtain warrant service:

To obtain warranty service please contact Customer Service at **1-800-505-1905** or via e-mail at customerservice@blinds.com.

THIS WARRANTY IS EXCLUSIVE AND IN LIEU OF ALL OTHER OBLIGATIONS, LIABILITIES, OR WARRANTIES.

MOUNTING HARDWARE KIT INCLUDES:

Mounting Bracket with Wing Nut

Width of Shade	Qty
18" to 42"	2
42 1/8" to 84"	3
84 1/8" to 96"	4

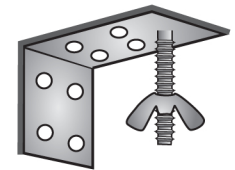

Bracket Screw – 1 inch

Width of Shade	Qty
18" to 42"	4
42 1/8" to 84"	6
84 1/8" to 96"	8



Cord Cleat and Screws: Provided with all standard cord lock shades. **All cords should be secured with cord cleats to prevent the risk of strangulation. Keep cords away from children and pets.**

Clutch Control Shades: Shades with clutch controls come with a continuous cord loop and are supplied with a cord tensioner, which should always be screwed to the wall. **Always secure cord loops to prevent the risk of strangulation. Keep cord loops away from children and pets.**

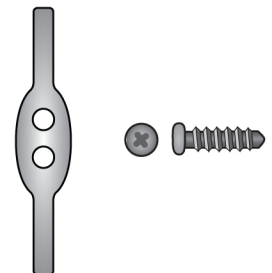

TOOLS THAT MAY BE REQUIRED:

Pencil, Tape Measure, Screw Driver, Step Stool, Level, and Drill

INSTALLATION:

NOTE: For wallboard or plaster, use anchors designed for hollow walls (not included). For concrete, stone and brick, use a masonry drill bit and anchors designed for masonry (not included).

FOR OUTSIDE OR WALL MOUNT:

1. Position brackets 1 to 2 inches from the end of the head rail. If provided, position middle brackets to align with pre-drilled holes in the head rail.
2. Hold the shade in place and mark the desired bracket locations with a pencil. Use a level to ensure the brackets are straight.
3. Pre-drill the mounting holes into the mounting surface. Next, screw the brackets in place into the mounting surface. [figure 1]
4. Hold the shade so that the screw posts on the brackets fit through the slots in the head rail and re-attach wing nuts and screw tight to hold the head rail firmly. Make sure the shade is level. [figure 2]

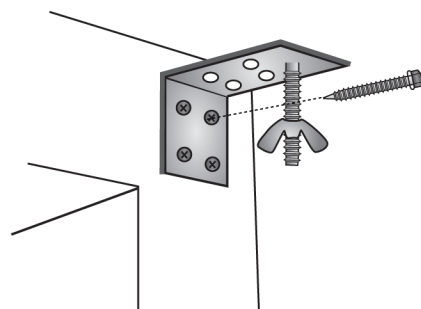

[figure 1]

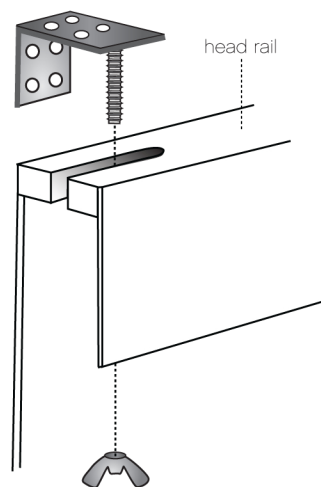

[figure 2]

FOR INSIDE OR CEILING MOUNT:

1. Position brackets approximately 1 inch from the ends of the head rail. If provided, position middle brackets to align with pre-drilled holes in the head rail.
2. Measure 1 inch in from each side of the window frame and mark bracket locations with a pencil.
3. Pre-drill the mounting holes into the mounting surface. Next, screw the brackets in place into the mounting surface. [figure 3]
4. Hold the shade so that the screw posts on the brackets fit through the slots in the head rail and re-attach wing nuts and screw tight to hold the head rail firmly. Make sure the shade is level. [figure 2]

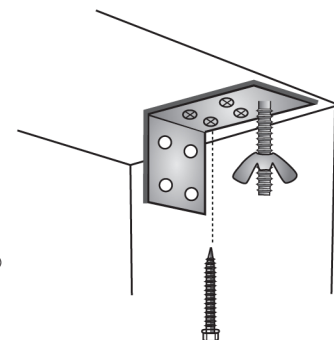

[figure 3]

INSTALLING THE CORD CLEAT:

Optional. Your shade is fitted with a cord lock, which allows the shade to stay in whatever position you desire. However cord cleats help keep cords tidy and away from children. **We strongly recommend the use of cord cleats to help prevent the risk of strangulation.**

1. Find a convenient place about 1 inch out from the side of the shade where the cords are located and about one quarter of the way up from the bottom of the shade.
2. Hold the cord cleat parallel with the frame of the window. With a pencil, make a mark through the holes.
3. Make pilot holes and install cord cleat with 2 screws.